

Xenos Armies

for Titan Legions 2nd Ed.

Revision 1.2

Disclaimer: This book was written by no one of importance as a tribute to all of the wonderful sci-fi movies of the past. It is a completely derivative work of fiction and is completely unofficial and in no way endorsed by Games Workshop Limited. Warhammer 40,000, Adeptus Titanicus, Space Marine, Epic 40,000, Epic: Armageddon and other names, races, from the Warhammer 40,000 universe are either ®, TM and/or © Copyright Games Workshop Ltd 2000-2005, used without permission and their use should not be construed as a challenge to said ownership.

Table of Contents

Background	3
New Weapons and Equipment	4
Eye Horror Army	5
Unit Descriptions	5
Unit Summary	6
Eye Horror Army List	7
Oculus Titan	8
Oculus Titan Weapon Options	9
Soul Spider Army	10
Unit Descriptions	10
Unit Summary	12
Mega-Monster Description	13
Mega-Monster Template Chart	14
Mega-Monster Augmentation Chart	15
Mega-Monster Weapon/Modification Description Table	16
Mega-Monster Damage Chart	18
Soul Spider Army List	19
Soul Spider Unit Command/Instinct List	20
Psi-Bug Cards	21
Master Geneticist Cards	22
Oturuk Hive Army	22
Unit Descriptions	22
Unit Summary	24
Oturuk Hive Army List	25
Exterminator Titan	27
Hecaton Titan	28
Oturuk Titan Weapon Options	29

Back Ground

Some 20+ years ago I happened upon a copy of White Dwarf adorned with the newly minted Great Gargant on the cover. I've loved Titan Legions every since. Unfortunately, the remake of the game did not do well and led the the eventual discontinuation of the game. Gone is the anticipation of a new unit or new army's release. There will be no new armies, no new books, no new game, and no new players. Although my love of the game has not changed, I can not share the game with new players. Who could afford to buy, piece by piece, an out of production army?

This book is a small attempt to create new, easily made, armies for Titan Legions 2nd Ed. When I decided to do this book there were any number of possibilities from Chaos Squats and Undead to lesser known races from the original Rogue Trader. I naturally assumed that anything I could think of had probably already been attempted. To further complicate things, I no longer have an active group to play with. This forced me to consider an automated army which brought up the idea of the old monster movies, which led to horror movies, and old sci-fi B movies.

Here is the result. Three armies that can either be easily made (Eye Horrors), easily found (giant monsters for the Soul Spiders), or generically substituted (Oturuk). Enjoy.

History of the Xenos:

Many are the legends of great battles fought by the early Imperium of Man. In these early legends, great alien empires were crushed beneath the weight of the Adeptus Astartes, but there is little to describe either the alien armies or what happened to them. Not all of these alien empires simply ceased to exist, some still haunt the dark spaces between the stars. They wait for their chance to strike back at an enemy that no longer remembers they ever existed.

Three ancient empires, their home-worlds lost or destroyed, fleets in tatters, and armies reduced to ashes chose to join forces rather than simply die away. Together they forged giant asteroid bases capable of surviving in the harshest recesses of the galaxy. This allows the base to simply blend in with it's surroundings. From these hidden bases, they would raid nearby civilizations for information, technology, and materials. They would rebuild their armies, refine their technology, and wait for their chance to return. They chose not to give the ships any name. Instead, they refer to them collectively as Planet X.

Oddly enough, none of these old empires are tempted by the lure of chaos. Perhaps they follow their own deities or hold their own perversions above what the chaos gods could offer them. Deep in the heart of the ancient libraries, some sages whisper they are not tempted by chaos because they simply have no soul to begin with. What ever the case, they will cleanse chaos infested worlds.

The first empire of this dark triumvirate was referred to in the ancient histories of the Imperium simply as the Eye Horrors. The Horrors are massive floating leathery bags with a giant eye capable of seeing even in the darkest of nights. From their body trail poisonous tentacles ending in metal piercing barbs or flesh cleaving claws. What type of world they came from is unknown, but their hunger for sentient flesh still lingers to this day. Worlds the Horrors raid are stripped of their populations to be used in gristly feasts. Horrors have little interest in holding a world, they take what they want and then leave. They seldom try to fight a well armed foe.

Horrors developed some of the earliest knight units. Today, they form the backbone of their army. These heavy units are backed up with a few skimmers and the Eye Horrors themselves. Although they have a good average hand to hand capability, they lack specialized units and will suffer against close combat oriented troops.

No less bizarre are the Soul Spiders. The name "Soul Spider" is a translated name from ancient Eldar texts. The Eldar considered their empire a minor nuisance with the tenacity of a cockroach. Despite repeated efforts, neither the Eldar, nor the Imperium of Man could completely wipe them out. The Eldar gave the Soul Spiders their name from their strange habit of eating and preserving brains of sentient creatures. The spiders developed on a death-world and adapted their neural network into something resembling a massive CPU with rudimentary intelligence. They could eat the brain of a creature to learn where it hid, what it liked to eat, and where it could find more. The problem was that non-sentient brains could not retain information or develop new technology very easily. Their society lingered in this quasi-sentient state until another intelligent species developed on their planet. This second race was quickly conquered and used as a breeding pool for brains. Although intelligent, it would often take multiple brains to function at a normal human level. As the Soul Spiders spread from their home world, they quickly discovered superior brains to eat and coveted them.

Soul Spiders raid for brains. The more educated the brain, the greater their worth. They gain access to all knowledge from the brain, but not psionic abilities. Soul Spiders will not consume chaos tainted brains. These are considered to be "spoiled". Once the spider has the brain, they gladly give the left over carcass to the Horrors.

Soul Spiders are masters of mutations and genetic alterations. Their preferred method of attack is to create giant, radiated monsters or swarms of genetically altered horrors to release on a planet. In the ensuing havoc, they raid other areas for prized brains leaving before the planetary defenders have discovered the subterfuge. Their mechanical technology is no more advanced then the Imperium's. Sometimes they will add a battle fortress to the back of a quadruped beast for additional firepower. In addition to the monstrous beasts, they also use small, fast units to capture and hold key points on the battlefield.

The final army is somewhat more conventional. The Oturuk Empire is a bug-eyed, snouted, bipedal race that specializes in beam weaponry. It is believed that they originated as a slave race to a more technology savvy society. At some point the master race was destroyed, releasing the Oturuk to their own free will. Unfortunately, they were only made for war. They have a semi-hive mind and seem to work tirelessly at creating new weapons to wage war. When they raid a planet, the living inhabitants are only distractions to collecting

raw materials. While the other empires concentrate on stripping the populace, the Oturuk strip the mineral wealth.

Oturuk have line infantry, battlesuits, tanks, and superheavies. All sport strange beam weapons and blasters. To support their line troops, they drop fortifications from orbit. The Oturuk, if given the order, descend on a planet like locusts. They usually follow the initial assault by another empire to solidify the hold on a planet.

New Weapons and Equipment:

Abduction Ray: The Abduction Ray is a short range gravitation beam used to forcibly abduct infantry units. A unit in base to base contact under the saucer can be stolen. Roll to hit as normal, if the infantry unit is hit, it must save with no modifier. If it fails, it is destroyed (or more specifically used as food).

Disintegrator: A disintegrator fires a charged ball of positrons at a target causing impressive damage and a large explosion (even if the original target survives). Roll to hit as normal, if the target is hit, save versus armor with a -2 modifier. If the target survives or not, place a barrage template centered on top of the target and roll to hit any model at least half covered (including the original model). If the model is hit, roll to save with no modifier. Note: this is a direct fire weapon, not a barrage. It cannot be combined with other barrages or disintegrators, although multiple disintegrators can target the same model. Each must roll to hit individually. If facing matters, the barrage template hit originates at the center of the barrage template. The heavy disintegrator is a larger version used on the Ghoul superheavy tank and the Exterminator titan. The barrage template hit is capable of damaging buildings.

Mega-Beam: A mega-beam is a heavy laser capable of firing for an extended period of time. The weapon carves a straight line across the battlefield, destroying anything unfortunate enough to fall under it. In practice, the beam is represented by a straight line, 10 centimeters in length, placed in range and line of sight of the firing unit. Any model the line crosses will be hit on a 4+ and must make an armor save with a -1 penalty to the roll. If fired only at a titan with a shield, the shield loses 1d3 points but the titan will be untouched. If fired at a titan with no shield, pick a location and roll deviation as normal. If it results in a hit, there is a chance of a slash to an adjacent area. Roll the deviation dice again, if it results in a deviation to another titan location, both locations are hit and must save. If a Mega-beam just crosses a titan, it can only cause a single hit or remove one shield.

N-field: A unit may only have one N-field. An N-field will have a power rating of 1-8. It requires a weapon with at least a -1 save modifier to damage. On a successful hit, each -1 of the save modifier from the hit is deducted from the N-field's power rating. This reduces the save modifier of the shot until either the shield or the save modifier is reduced to zero. If the save modifier of the shot is reduced to zero, the shield has stopped the shot. If the shield is reduced to zero, the shot hits the model but only with the save modifier that remains. If the shot and the shield reach zero at the same time, both the shot and the shield fail. During the end phase, roll a d6, on a 4+ one point is regenerated, if this is successful the player may roll another d6, if the result is 5+ another point is regenerated, if this is successful, roll another d6, if the result is 6+ a final point is regenerated. N-fields grant a 4+ save vs psychic abilities as power shields.

Quantum Beam: A quantum beam is the primary armament of the Thorg Tank. The main reactor of the tank feeds power into a storage container. The less power the tank uses for movement, the more power can be stored up. For each point stored, the beam gains a -1 save modifier on a successful hit. All stored power is used when the Quantum Beam fires. On a charge order, the power that normally feeds into the storage tank is instead shifted to the hull of the tank. The extra power temporarily increases the damage of the vehicle in close combat (+1 caf for the first close combat). The maximum power that can be stored is 4 points for the Thorg tank and 6 points for a Exterminator Titan. The Thorg tank can store 1 point on advance orders or 2 points on first fire orders. The Exterminator's reactor is able to feed more power into the storage tank, so it gains 2 points on advance or 3 points on first fire. The Exterminator stores no energy on a charge but does gain a +1 caf and an additional +1 caf per combat arm option taken.

Scatter field: The scatter field is based upon deflection technology. It causes the space around the vehicle/titan to warp. Instead of absorbing the hit, it causes the path to warp and twist. This allows for a 6+ fixed save (taken before armor save) and a -1 to all to hit rolls targeting the vehicle. Against barrage weapons, it reduces the total barrage points by 1. Scatter fields give no psychic save.

Stealth Shield: The Stealth Shield is used to allow a saucer to avoid detection while infiltrating a planet's defenses. On the battlefield, it confuses weapon targeting systems and makes the saucer nearly invisible for a short time. The shield is not perfect and can be penetrated over time. As such, the shield will give a fixed saving throw of 2+ on the first turn, but will degrade by one point each turn. So the save slips to a 3+ fixed on the second turn, 4+ fixed on the third turn, etc until a maximum of 6+ fixed is reached. The shield is never reduced below a 6+.

Tentacles: The Eye Horror knights are not very good versus a determined and powerful close combat assault. They were never intended to be. They were intended to crush multiple, poorly equipped defenders. The way they accomplish this is by using multiple tentacles as not only their primary form of locomotion, but also for offense and defense. As such, they are never outnumbered in close combat.

Thunder Gun: The Thunder Gun is a horrid weapon that builds an increasing charge on a target until the target is destroyed. On a successful hit, the gun locks onto the target and requires no further roll to hit on successive turns as long as the target stays within the line of sight. On the first successful hit, the target must save at -1 or be destroyed. Each successive turn, the target will be hit at the beginning of the first fire phase with an additional save modifier of -1 per turn on target. So, on the first turn they must save at -1, on the second turn

they must save at -2, on the third turn it must save at a -3, etc. The maximum save modifier is a -6. The Thunder Gun can only fire on First Fire command. If the target leaves maximum range or moves behind an obstacle that totally hides the target, the lock on is broken and the Thunder Gun must start over. Note the thunder gun only causes one hit per turn.

Venom: An envenomed unit has a potent poison usable against a living unit. In any hand to hand combat tie, the envenomed unit wins. Wounds to living units cannot be regenerated if caused by an envenomed unit.

Eye Horror Army

Eye Horror Army Organization

The Eye Horror army uses the same basic organization as most armies. The army is composed around company cards. Each company card can bring up to 5 support cards and up to one special card. All psychological rules apply including unit cohesion and break checks. The army must be at least 75% composed of units from the Eye Horror army list. Up to 25% of the army can be borrowed from allied army lists (Soul Spider or Oturuk).

Eye Horror Unit Descriptions:

Eye Horror: The anatomy of an Eye Horror is confusing at best. They are giant, armored eye-balls that use a natural anti-gravity to float along. They trail tentacles with the tensile strength of steel cables that they use to rip men out of their armor. In close combat they can easily take on a 5 man imperial guard squad. Their eye has a natural ability to store and discharge polarized light. Although short ranged, it is very accurate.

Great Horror: A Great Horror is an ancient Eye horror that has grown to enormous size. They are always found in a position of command and often act as an ad hoc command structure during large battles.

Beholders: This odd walker is made of multiple legs and a gyro-mounted eyeball. The pilot sits within the eye and deftly maneuvers this fast vehicle into close range to deliver a powerful double blast from it's multimelta.

Harvester: The harvester is used to flush entrenched units out of their hiding hole. It is the fastest ground unit the Horrors can field.

Seeker: The seeker uses fast firing blasters to hunt down anything that dares move in its range of vision. Similar to Stunty Superheavies, the Seeker can never charge, but is always on first fire. A unit of Seekers appear as slow moving, floating eye-balls covered in small antennas that help them locate and lock onto targets extremely fast. Seekers are independent and require no orders.

Saucers: Saucers are classic Sci-fi movie flying saucers. They have a stealth shield that is used to degrade enemy targeting and visual identification. Although this shield eventually deteriorates, it is often enough time for the saucer to infiltrate a planet's defenses unnoticed or to wreak havoc on a battlefield. It's primary armament are twin lascannons, but it is also armed with a neural neutralizing abduction beam that can be used at low flying levels. Units stolen are considered destroyed.

Evil Eye Knight: The Evil Eye is a heavy support knight based on the basic giant armored eye supported by mechanical tentacles design. It's primary weapon is the devastating Mega-beam.

Eye Tyrant: The Eye Tyrant is a close combat variant of the Gorgon. It carries a pair of power pincers to augment it's close combat capability and has a variety of close in weapons, including a heavy meltagun.

Cyclops Knight: The Cyclops is a heavy support knight very similar to the Evil Eye. They are often indistinguishable until it fires its Gamma-laser. The Gamma-laser is an extremely long ranged and accurate beam weapon. Although lacking the punch of a defense laser or Quake cannon, it has a longer range.

Gorgon: The Gorgon is one of two mass produced knights that form the bulk of the Eye Horror army. The basic Eye on tentacle design is supported by a potent plasma beam. Gorgons are the preferred knight when facing massed heavy tank opponents, but suffer at long range.

Medusa Command Knight: High commanders use an improved version of the Watcher knight. This deadly knight has range, speed, and the highest close combat capability in the Eye Horror army. It's eye and tentacle design is augmented with a pair of deadly ripping claws.

Observer Knight: The Observer is the main knight used by the Eye Horror army. It mounts a beam similar in effect to an imperial battlecannon and has the classic eye and tentacle design. As a generic knight it performs admirably at range and in combat against multiple, poorly equipped, units.

Watcher Knight: A heavier version of the Observer, the watcher mounts two additional blasters. Watchers are often used as close in fire support when facing infantry heavy armies.

Eye Horror Units:

Unit	Move	Save	CaF	Weapon	Range	Attack	To Hit	Save Mod	Special
Infantry									
Eye Horror	10cm	None	+1	Eye flash	25cm	1	4+	0	skimmer
Great Horror	15cm	6+ fixed	+2	Eye flash	25cm	2	4+	-1	Command, skimmer
Walkers									
Beholder	25cm	4+	+1	Multimelta	35cm	2	3+	-4	walker
Tanks									
Harvester	35cm	5+	+1	Flamer	template	1	4+	-1	Skimmer, flamer
Seeker	15cm max	3+	+2	Blasters	50cm	3	5+	-1	Skimmer, first fire, N-field (1)
Fliers									
Name	Move	Save	CaF	Weapons	Range	Att.	To Hit	Save Mod	Special
Saucer	35cm	3+	+1	Lascannons Abduction Ray	75cm 0cm	2 1	5+ 4+	-1 0	Stealth shield, flier, independent
Knights									
Evil Eye	15cm	3+	0	Mega-Beam Mini-beam	100cm 10cm	Templ. 1	4+ 6+	-1 0	Superheavy, Knight, Tentacles, N-field (3)
Eye Tyrant	25cm	3+	+3	Meltagun Scatterlaster	35cm 25cm	1 3	3+ 4+	-3 0	Superheavy, Knight, Tentacles, N-field (2)
Cyclops	15cm	2+	+2	Gamma-laser Mini-beam	125cm 10cm	1 1	3+ 6+	-2 0	Superheavy, Knight, Tentacles, N-field (3)
Gorgon	20cm	3+	2	Plasma Beam Mini-beam	50cm 10cm	1 1	3+ 6+	-3 0	Superheavy, Knight, tentacles, N-field (2)
Medusa	25cm	2+	+4	Eye beam Meltagun	75cm 35cm	2 1	4+ 3+	-2 -3	Superheavy, Knight, tentacles, N-field (4), HQ
Observer	20cm	3+	+2	Eye Beam Mini-beam	75cm 10cm	1 1	4+ 6+	-2 0	Superheavy, Knight, tentacles, N-field (2)
Watcher	15cm	3+	+2	Eye Beam Blasters	75cm 50cm	1 2	4+ 5+	-2 -1	Superheavy, tentacles, Knight, N-field (3)

Eye Horror Cards

Company Card	Composed of	Break point	Moral	Victory Points	Cost
Observer Horde	1 x Command Observer 2 x Observer Pods	4	3	5	500
Gorgon Horde	1 x Command Gorgon 2 x Gorgon Pods	4	3	5	500
Support Cards					
Beholder Pod	5 x Beholders	3	3	3	250
Evil Eye Pod	3 x Evil Eyes	2	3	5	500
Eye Horror Pod	10 x Eye Horrors	5	3	2	150
Eye Tyrant Pod	3 x Eye Tyrants	2	3	2	200
Cyclops Pod	3 x Cyclops	2	3	5	500
Gorgon Pod	3 x Gorgons	2	3	3	250
Harvester Pod	5 x Harvesters	3	3	2	150
Observer Pod	3 x Observers	2	3	3	250
Seeker Pod	5 x Seekers	3	3	4	400
Watcher Pod	3 x Watchers	2	3	4	350
Special Cards					
Great Horror	1 x Great Horror	1	3	1	50
Medusa	1 x Medusa	1	3	2	200
Saucer Pod	2 x Saucers	1	3	3	300
Oculus	1 x Oculus Titan	1	-	6	400+



Oculus (EYE) Titan

The Oculus Titan is the pinnacle of the Eye Horror technology. Faced with the continued threat from Eldar titans and the new threat from the Warlord Titans from the newly formed Imerium of Man, the Eye Horrors pushed their knight technology to the limit and created the Oculus Titan. Although this did not stop the fall of their empire, the titan shares much of the technology of the knight units making it easy to maintain with limited resources. The titan consists of a large, heavily armored, eye riding on an armored base, supported by four legs. The titan's giant eye is a turret capable of turning in any direction. This allows the main beam weapon to be used in any direction. The eye also houses the titan's plasma reactor and command center.

The hull contains the titan's N-field generator and secondary weapon systems. Unlike the giant eye, all secondary weapons have only a 90 degree angle of fire from the front of the titan. Each of the titan's 4 legs are connected to the hull giving the titan excellent stability but very slow movement.

As a titan, the Oculus has more power to regenerate it's N-field. The Oculus rolls a 3+ for the first point, 4+ for the second, 5+ for the third, and a 6+ for a fourth and final point.

Titan	Movement	CaF	Shields	Weapon Options	Cost
Oculus	10cm	+6	N-field (8)	One secondary	400+
Weapon	Type	Location	Description		
Primary Weapon	Heavy	Eye	Primary weapon, 360 degree field of fire		
Secondary Weapon	Secondary	Hull	Hull mounted weapon, 90 degree forward fire angle.		
Secondary Weapon	Secondary	Hull	Hull mounted weapon, 90 degree forward fire angle		

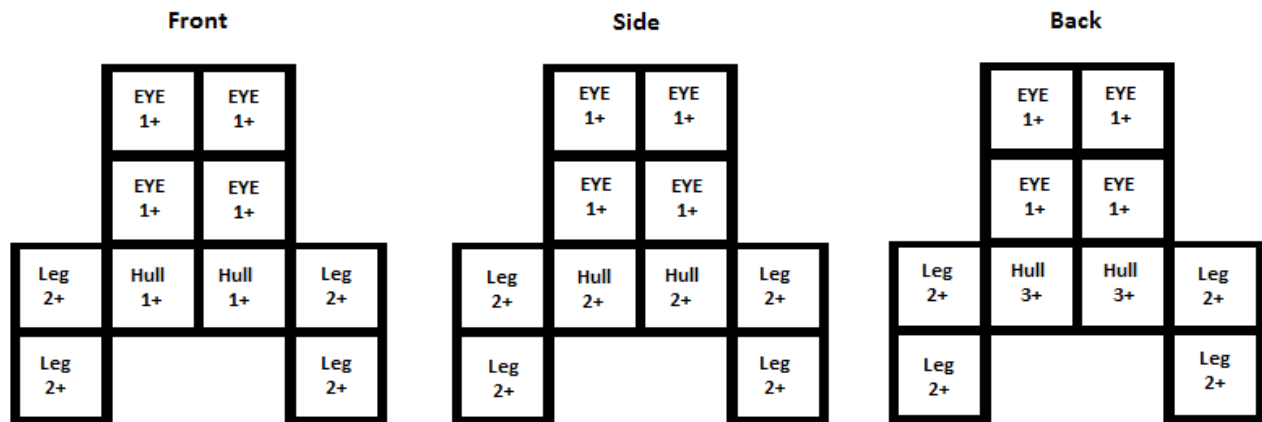

Oculus Hit Location

D6	Eye	D6	Primary Weapon	D6	Hull	D6	Leg
1-2	Primary Weapon	1	Plasma ray damage and fires at -1 to hit until repaired in end phase on 4+	1-2	Secondary weapon damaged. Repair on a 4+ during end phase.	1-2	Damaged, speed halved and cannot enter difficult terrain.
3-4	Command	2-3	Weapon damaged can not fire until repaired in end phase on 4+	3-4	Secondary weapon destroyed, N-field generator damaged and shuts down, repair on 4+ during end phase.	3-4	Damaged, Roll d6 in each end phase; subtract 2 for charge orders, 1 for advanced orders. A result of 0 or less, the leg snaps and titan falls (destroyed).
5-6	Reactor	4-5	Weapon Destroyed	5	N field generator overloads and destroys the titan on 4+, on 1-3 titan suffers same result as 3-4 (above).	5	Destroyed leg. The titan may no longer move or turn.

		6	Weapon destroyed and titan suffers damage to command (1-3) or reactor (4-6).	6	N-field generator overloads destroying the titan.	6	Destroyed leg, titan crashes to the ground and is destroyed. (ignore on first destroyed leg, treat as 5 above)
D6	Command			D6	Reactor		
1-2	Command Damaged, titan uses random orders until fixed 4+ during end phase.			1-2	Reactor damaged. Titan can only fire secondary weapon while moving and Plasma Ray can not be fired on Max power until fixed in end phase on 4+		
3-4	Command damaged, Move/shoot on 4+ for the rest of game			3-4	Reactor damaged. Titan moves at half speed, loses half of its CaF, can not regenerate its N-field during end phase and Plasma Ray can not be fired on Max Power or High Power.		
5-6	Command destroyed. Titan collapses.			5-6	Reactor goes critical destroying the titan. Any model within 2d6cm takes a hit on 4+ with a -2 save modifier.		

Oculus Titan Weapon Options

Weapon	Range	Attack Dice	To Hit	Save Mod	Other	Position	Cost
Plasma Ray					Primary Weapon	Primary	125
Low Power	50cm	3	3+	-2	No restrictions		
High Power	75cm	4	3+	-3	First Fire Only		
Max Power	100cm	4	3+	-4	First Fire only, no other weapons, No move next turn.		
Heavy Disintegrator	100cm	1 temp.	3+ 5+	-3 -1	Primary hit secondary explosion	Primary	100
Mega-Beam	100cm	Temp.	4+	-1	10cm line	Primary	100
Electro-Field	Touch	-	3+	-1	Roll before close combat during close combat phase, targets all models in base contact.	Secondary	25
Blaster Beam	50cm	1	3+	-3	90 degree forward angle	Secondary	25
Disintegrator	75cm	1 template	4+ 5+	-2 0		Secondary	35
Twin Lascannons	75cm	2	5+	-1	90 degree forward angle	Secondary	25
Plasma Missile	75cm	8bp	8bp	-4	One shot, standard barrage template	Secondary	15
Tentacles	Close combat				Never outnumbered, +1 CaF	Secondary	20
Giant Claw	6cm	1	3+	-3	Adds +1 to CaF	Secondary	25

Oculus Titan Weapon Descriptions:

Plasma Ray: The fearsome plasma ray is a focused plasma accelerator used to melt enemies at a distance. It pulls power directly from the plasma reactor of the titan and has a variable firing pattern depending on how much power is available. While using the other weapons and moving, the beam can only fire on Low Power. If the titan has stopped moving and is using first fire orders, it can use more power and fire on High Power. In order to use Max power, the titan must be on first fire orders and not use any other weapon, it also cannot move on the following turn.

Heavy Disintegrator: This is the titan sized version of the standard disintegrator. Although not as powerful as the plasma ray, it does not

suffer from variable power.

Mega-Beam: A mega-beam is a heavy laser capable of firing for an extended period of time. The weapon carves a straight line across the battlefield, destroying anything unfortunate enough to fall under it. In practice, the beam is represented by a straight line, 10 centimeters in length, placed in range and line of sight of the firing unit. Any model the line crosses will be hit on a 4+ and must make an armor save with a -1 penalty to the roll.

Electo-Field: The titan is surrounded by a crackling aura of energy which easily incinerates any enemy that gets too close. During the close combat phase, before any close combat, any enemy unit in contact with the titan is hit on a 3+ and must make an armor save at a -1 or be destroyed. Those that survive may conduct close combat as normal. A titan (or other shielded unit) will lose one shield. If it is not shielded, it suffers one hit (roll for deviation) and must save at a -1.

Blaster Beam: This is a heavy blaster that trades range for power. It is a secondary weapon.

Disintegrator: This is a standard disintegrator used as a secondary hull weapon.

Twin Lascannons: Two lascannons used as secondary weapons.

Plasma Missile: The plasma missile is a large, one shot plasma missile used to melt an area. It counts as a barrage, can be fired indirectly, and can destroy buildings.

Tentacles: The titan gains little additional CaF, but is never outnumbered in close combat.

Giant Claw: The titan has a huge claw mounted on a telescopic arm that is used to reach out and crush its enemies. If not pinned in close combat, it can make one attack up to 6cm away from the titan during the close combat phase. If it hits and the target does not save, it can be tossed at another unit within 15cm of the titan. The new target is hit on a 5+ and is destroyed if it has an armor save less than the thrown unit. The claw cannot be used to pick up superheavies or titans but can still attack and damage them. If the titan is pinned or does not use the claw for a grab attack, it adds +1 to the titan's CaF.

Soul Spider Army

The biology of the Soul Spiders is confusing at best. They develop through two very distinct phases. The first is similar to a grub that can range from the size of a human thumb to as large as a dog. They are usually allowed to burrow into live hosts where they will take one of two paths. If the grub is of a lower sentience, they burrow their way into the host creature's brain and take control of it. The host will then act in any manner the grub wishes. If it is capable of stealing a brain, it instead begins to eat the host body, rapidly growing in size as the host deteriorates. It eventually bursts from its host and in its final act, before the host can die, it eats the brain. As such, sentient hosts are preferred. The grub then pupates into the heavily armored adult form.

A majority of the young are of the lower sentience and are used to control the various monstrosities created. Each monstrosity has a grub deep in its brain that has eaten and replaced the monster's own consciousness. This allows for many of the soul spider units to act independently. Those few that can rise in intelligence are allowed to grow to adulthood. Adult soul spiders continue their brain collecting and training of mechanical or bio-mechanical technology. Being few in numbers, they seldom join a fight, but when they do, they are typically very heavily armed. There are never enough adults to make an army of just soul spiders so they only serve in a support role to their monstrous creations.

Soul Spider Army Organization:

Soul Spider armies are based around swarms of small (man sized) monsters, giant Mega-monsters the size of titans, or combinations of everything in between. On rare occasions, a mechanical soul spider unit might be added to increase the control of the army or to serve in a special role. Although units must maintain unit cohesion, the command structure is a bit different. Units that are within command radius can receive orders as usual. Units that are outside of command radius fall back on instinctive orders. If a Mega-Monster is present, a unit out of command that can see a Mega-Monster can mimic the monster's orders. All Mega-Monsters are considered command units for the purpose of giving orders only. Mega-Monsters are immune to all psychology.

Soul Spider armies are organized the same way as most other armies. Each army starts with a company card and may add up to 5 support cards and one special card per company card. Soul spider armies can only ally with other Xenos armies and can bring up to 25% of their army as allies. Due to the distraction action of the army, every two turns the game lasts, the soul spider army gains 1 victory point to a maximum of 3 points to reflect the brain harvesting taking place off board.

Soul Spider Unit Descriptions:

Black Widow: The Black Widow is an adult Soul Spider armed for long range combat. Due to the size of the spider, it serves the role of a fire support dreadnought. They sport a lascannon and a scatter laser, but suffer in close combat. All Soul Spiders have a nasty venom which allows them to win in any draw close combat result. They also ignore terrain restrictions except for water.

Wolf Spider: The Wolf Spider is a hunter killer. An adult trained in close combat and augmented with bionics, robotics, and close combat enhancements. They have the same venom as the Black Widow allowing them to win any Close Combat tie and also ignore terrain restrictions except water. If a Wolf Spider unit defeats a living, non-chaos unit in close combat and survives for the rest of the game, it gains +1 victory point (by collecting fresh brains).

Brain Bug: The homeworld of the brain bugs was invaded long ago by the Xenos armies. Their strange insect/psionic brains were unattractive to the tastes of the Soul Spiders and their poisonous flesh was inedible to the Eye Horrors. If it had not been for the Soul Spiders' recognition that their psionic powers could be useful, they would have simply been exterminated. The current incarnation of the brain bug has been genetically altered from that early race to increase the potential of their psionic abilities as well as their loyalty to their Xenos masters. Each brain bug is randomly allocated 2 brain bug cards to be used during the battle.

Master Geneticist: There are mad scientists, there are insane geniuses, and then there are multi-brained, alien bug, monster producing, atrocities. Master Geneticists fall into the last category. Sometimes a Soul Spider manages to gather a large number of potent brains together forming a mobile version of a mad scientist think tank. They are always working on something new and it is never good for target of their interest. These cards cannot be used on Mega monsters. Only one Master Geneticist is allowed in your army per 2000 points.

Master Geneticists are command units for all three armies (generally out of fear of being their next experiment). They also gain one random mutation card to be used as they see fit during the game. Finally, due to their brain power, they gain a 3+ psychic save.

Abominations: It is hard to describe an abomination due to most of them being made from the combined, horribly mutated, parts from multiple different creatures. Although they may look different, the result is the same. Abominations are incredible strong, killing machines on par with ogres, genestealers, or minotaurs. Uncontrolled abominations always charge toward the closest enemy living unit. If they are uncontrolled and there are no living units on the board, they will simply stay where they are, even if being shot (but they will gladly fight back in close combat).

Arachnid/Bug: These are large, mutated, monster bugs/spiders/scorpions the size of a small car. They ignore terrain, except for water and charge toward any living unit if uncontrolled. If there are no living units, they will charge toward any enemy unit that moves/fires.

Armored Beast: Armored Beasts are the size of a large dinosaur and are typically covered in a bony hide. Armored beasts are easily the match of a tank in close combat. Uncontrolled beasts will charge toward the nearest living enemy unit. If there are no living units, they will charge toward any enemy unit that moves/fires.

Shamblers: Shamblers are usually zombies made from the local populace. They have a low intelligence, no ranged weapons, and are not very impressive in close combat, but they are very easy to make and are deployed in large numbers to swarm over an enemy.

Large Beast: These creatures are oversized versions of regular carnivorous terrestrial animals. Examples would be giant wolves, snakes, or lizards. They retain slightly more intelligence than the other swarms and can be given regular orders even without a command unit.

Shepard: The Shepard is a flying superheavy used as both a mobile command center and a troop movement vehicle. A very high tech and versatile unit, it is also very rare. If it is on the battlefield, it may give orders to any unit within 25cm. If it is within 10cm of a mega-monster, it may not be targeted (command rule).

Soulreaper: The Soulreaper is a heavily modified Shepard used to move a larger number of units. It is not a command unit and does not get the additional command rule benefit for being next to a Mega-monster.

Dragon: The dragon was genetically engineered to mimic the human legends of Terran dragons. They are fully capable of flight, but most prefer to hunt on the ground. Dragons are engineered to be very intelligent and act independently.

Gigantic Beasts: A gigantic beast is a heavily enlarged and mutated creature rivaling a superheavy in size. They often accompany smaller swarms of similar creatures to help remove stubborn resistance. They are incredibly destructive in close combat, using their size, weight, and natural ferocity tear apart even heavily armored tanks. To make matters even worse, they are capable of attacking a building (save at -1 or be destroyed). Gigantic beasts rampage upon death. A gigantic beast's armor save can never be modified above a 6.

Hydra: The hydra is a multiheaded monstrosity from legends reborn from the genetic kiln of the soul spiders. It is the size of a banesword. If the hydra suffers a wound and fails to make its armor save, place it on its side until the end phase. During the end phase, the hydra regenerates on a 4+. If the model regenerates successfully, it gains a +1 caf. If it fails, remove the model. The hydra can regenerate against all forms of attack (range, close combat, and even psychic effects) except flamer attacks.

Radioactive Beast: This is a gigantic beast that has been further modified into a radiation spewing horror. While a gigantic beast must close and rip things apart, the radioactive beast will simply melt things using gamma radiation powered beams.

Blob: The blob is an uncontrolled horror that will eat friend and foe alike. This unnatural creation is incredibly resistant to beams, projectiles, and bombardments using a fixed 3+ save versus all of them. Only area effect weapons (flamers, gargant steam attack, etc) can modify the save. (I.E. if it is hit with a flamer with a -1 save, it saves on a 4+). The blob always wins in close combat doing an unmodified hit to any unit in contact or within the blob. If the unit survives, it loses 1 from its save due to the blob slowly dissolving it (so a tank that saves on a 3+ that survives contact with a blob would have its save reduced to 4+). Any unit covered or in contact is considered pinned except for praetorians and titans. Any unit that is pinned is swept up with the blob as it moves. The units are only released when destroyed or if the blob is destroyed.

Any time the blob destroys a living model it gains one wound. If it reaches 6 wounds, it will split and form a new blob during the end phase. The blob is represented with a 6cm barrage template placed after all other models have been placed on the board. The blob is allowed to then move 10d6cm in any direction chosen by the Xenos player. After that, in the beginning of the movement phase, roll the direction die and 3d6cm. The arrow indicates the direction the blob will move. If the direction die shows a hit, the blob does not move that turn. A blob ignores all terrain and will attack friend and foe alike.

Tormentor: The Tormentor is the pinnacle of Soul Spider technology. It is a command superheavy that carries its own defensive shield. As long as it is within 10cm of a Mega-monster it benefits from the command rule (even if it is the closest target). Near all other units it uses the regular command rule. The Tormentor may command any unit or swarm that has a model within 25cm.

Soul Spider Units:

Unit	Move	Save	CaF	Weapon	Range	Attack	To Hit	Save Mod	Special
Infantry Units									
Black Widow	20cm	5+	0	Lascannon Scatterlaser	75cm 25cm	1 3	5+ 5+	-1 0	Venom, atv
Wolf Spider	20cm	5+	+3	Scatterlaser	25cm	3	5+	0	Venom, atv
Brain Bug	10cm	5+	+1	Psi-blast	35cm	1	5+	-2	Command, psi-cards, infantry, 4+ psi save
Master Geneticist	20cm	5+	+3	Lascannon Scatterlaser	75cm 25cm	1 3	4+ 5+	-2	Venom, atv, command
Swarm Units									
Abominations	10cm	6+	+5	Claws/Fangs					infantry
Arachnid/Bug	15cm	None	+1	Claws/fangs					Atv, infantry
Armored Beast	20cm	3+	+3	Claws/fangs					tank
Shamblers	10cm	None	0	Claws/fangs					infantry
Large Beast	25cm	6+	+2	Claws/fangs					Cavalry
Fliers									
Shepard	35cm	2+	+2	Lascannon Scatterlaser	75cm 25cm	1 3	5+ 5+	-1 0	Flier, independent, Carries 4 stands, Scatter field, HQ
Soulreaper	50cm	4+	0	Lascannon	75cm	1	5+	-1	Flier, Superheavy, carries 12 stands
Superheavies									
Dragon	25cm	2+	+7	Breath	Template		3+	-1	Flier
Gigantic Beast	20cm	1+/6+ fixed	+8	Claws/bite					Rampage
Hydra	20cm	2+	+6	Multiple heads					Never outnumbered, regeneration 4+
Radioactive Beast	15cm	1+	+5	Power Beam	75cm	2	3+	-3	
Blob	15cm max	3+ fixed	-	Acid absorption	Touch	Any	2+	-1	3 wounds, special rules, ignore terrain

Tormenter	15cm	1+	+3	Mega laser Scatterlaser	100cm 25cm	2 3	4+ 5+	-2 0	Superheavy, scatter field, skimmer, HQ
				Howdahs					
Command	-	3+	-	Command	-	-	-	-	HQ, 25cm range
Defensive	-	4+	-	Scatter lasers	25cm	3	5+	0	turret
Offensive	-	4+	-	Twin Lascannons	75cm	2	5+	-1	turret
Greater	-	3+	-	Blasterbeam Lascannon	50cm 75cm	1 2	3+ 5+	-3 -1	Fwd 90 turret
Bombardment	-	2+	-	Triple Plasma Bombard	25-125cm	3bp x3	3bp x3	-3	3 barrage templates, either in a row or combined.

Mega-Monsters:

Mega Monsters are the pinnacle of soul spider genetic technology. Using common stock animals, they create city crushing, army devouring, giant monsters. Although these biologically constructed titan terrors could probably conquer a world, the soul spiders prefer to use them as a distraction. Once released on a planet, the local defense concentrates on catching the rampaging monster while the soul spiders quietly harvest brains.

Mega-monsters require no command units. They are independent and act accordingly. Mega-Monsters can act as a form of limited command. Although they are not a command unit, their size and power cause lesser units to follow and imitate them. Any soul spider unit within 20cm of a Mega-monster can be given the same order as the Mega-monster.

Alpha, delta, and epsilon monsters can be equipped with howdahs on their backs to improve their offensive firepower. These miniature battle fortresses are attached to the monster's back and have no independent movement capability. When a megamonster equipped with a howdah is hit, randomize the shot between the howdah and the monster. On a roll of a 1 on a d6 the howdah is hit. On a roll of 2-6 the monster is hit and continue as normal. Howdahs share the same orders as the monster.

All Mega-monsters can attack buildings. The attack gains one save modifier per level of the monster (small is -1, medium is -2, large is -3, and Omega-King is -6). Each close combat attack option the monster has, if not used in close combat, adds an additional -1 to the save. The monster gains one free attack against any building, in base contact, during the close combat round each turn.

Alpha-The Beast: This beast is based upon land quadrupeds. Giant wolves, lizards, or amphibians are common basic stock for these Mega-monsters. Due to the 4 legged construction, the beast is very fast and suffers only minor inconvenience by loosing one leg. The Alpha is capable of supporting a howdah on it's back. This counts as the special card for the monster.

Beta-Floating Eye Ball: The Floating eye is a giant floating head/eye ball/mass of tentacles/etc that usually is heavily armed with ranged weapons. It is a skimmer but cannot do pop-up attacks.

Gamma-Walking Giant: The giant is the closest to a titan. Although usually lightly armed for range combat, they are the most devastating in hand to hand. Gammas are large, bipedal humanoids often armored with genetically engineered exoskeleton or even suits of adamantite armor.

Delta-Bug: The giant bug is a heavily armored beast capable of taking a lot of damage. Most are multi-legged monstrosities that carry crushing claws, jaws, tails, and a variety of other weapons. The Delta can also support a howdah on it's back.

Epsilon-Slug: The slug/snail/snake has little to offer offensively, but is generally incredibly hard to kill. The monopod body can withstand many more alterations than most other Mega-monsters. The Epsilon can also support a howdah on it's back.

Zeta-Flier: The flier is a titan sized beast capable of flight. Although not as strong as a land based Megamonster, the flier is capable of destroying most other fliers and causing havoc on ground troops.

Lambda-Swarm Progenitor: The Progenitor must accompany a swarm and has the same general appearance. It is considered to be the "mother of the swarm" and a command unit for the swarm. Although it does not benefit from the command rule, it can sacrifice a model from it's swarm to prevent a hit. The unit must be within 6cm of the model and must be chosen before rolling the saving throw. During the end phase, on a 4+ the Progenitor can create a new model for the swarm (abomination, arachnid/bug, shambler/large beast swarms only). The model is placed in base to base contact with the Progenitor.

Omega-King of Monsters: The Omega is the ultimate Mega-monster. It is capable of taking on groups of titans or an entire army without any support. Omega's are used for only one purpose, total destruction. Only an Emperor Titan would have a chance to stand alone against this beast. In addition to saving on 2 dice, the Omega can use a plasma ray on advanced orders, and suffers less damage on critical hits (-1 to die roll, treat a result of 0 as not critical damage).

Mega-Monster Template Chart

Monster	Move	Save	Caf	Wound	Close Combat	Either	Ranged	Body Mod	Cost
Alpha-Small	30cm	4+	+6	2	1	1	1	1	150
Medium	27cm	3+	+8	4	1	1	1	2	350
Large	25cm	2+	+10	5	1	1	1	3	500
Beta-Small	10cm	5+	+2	2	-	1	1	1	125
Medium	10cm	4+	+4	4	-	1	2	1	325
Large	10cm	3+	+6	5	-	1	3	1	500
Gamma-Small	25cm	5+	+8	2	1	1	-	1	150
Medium	22cm	4+	+10	5	1	2	-	1	350
Large	20cm	3+	+12	6	1	2	-	2	500
Delta-Small	20cm	3+	+5	2	-	2	-	1	150
Medium	17cm	2+	+7	4	-	2	-	2	350
Large	15cm	1+	+9	5	-	3	-	2	500
Epsilon-Small	15cm	5+	+4	3	-	1	-	2	150
Medium	12cm	4+	+6	5	-	1	-	3	350
Large	10cm	3+	+8	7	-	1	-	4	500
Zeta-Small	40cm	5+	+3	2	1	-	-	1	150
Medium	35cm	4+	+5	4	1	1	-	1	350
Large	30cm	3+	+7	5	1	1	1	1	500
Lambda-Swarm Progenitor	15cm	2+	+6	2	-	1	-	-	200
Omega-King	20cm	3+ (on 2 dice)	+22	12	3	2	2	6	1500

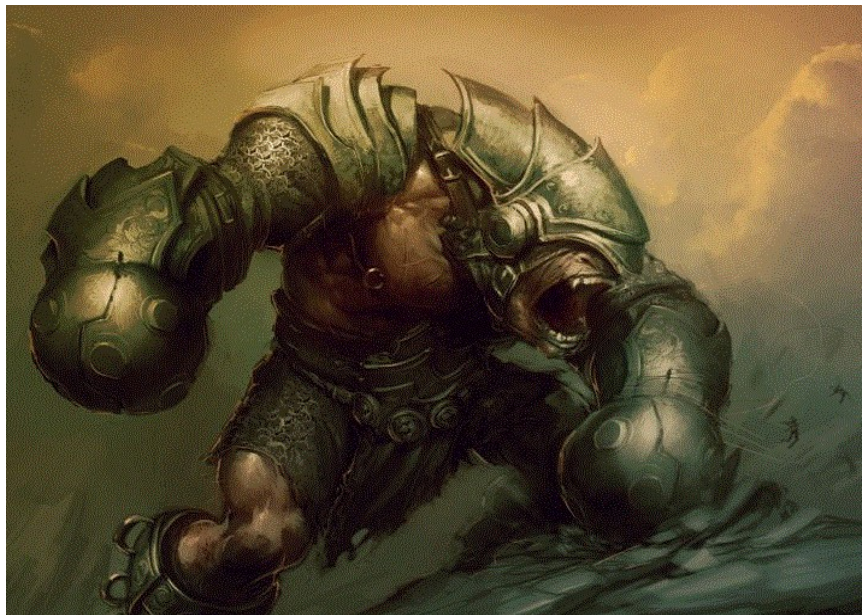

Mega-Monster Augmentation Chart

Weapon	Option Location	Effect	Cost
Close Combat Weapons			
Claw	Close Combat (arm)	+1d6 CaF	25
Club/sword.etc	Close Combat	Short ranged attack	50
Oversized Jaws/Pincers	Close Combat (head)	+1d6 CaF	25
Ram Head	Close Combat (head)	Ram Attack, 6+ fixed save on head	100
Scorpion Tail	Close Combat (tail)	Close Combat attack	25
Shield (Gamma only)	Close Combat	+1 armor save fwd, 6+ fixed fwd	25
Spiked Tail	Close Combat (tail)	+3 CaF	25
Tentacles	Close Combat	Never Outnumbered	50
Body Modifications			
Adrenal Reserve	Body Mod	+3d6cm on one charge	25
Augmented Weapon	Body Mod	Additional +1 caf, +1 damage, or -1 save for a single weapon	25
Bio-battery	Body Mod	Area effect R=12cm	75
Decimator	Body Mod	See description	50
Fast	Body Mod	+5cm move	50
Flying Leap	Body Mod	20+(1-10)d6cm	75
Heavy Armor I	Body Mod	+1 Armor Save	25
Heavy Armor II	Body Mod	+2 Armor Save	50
Impervious	Body Mod	Always saves on 5+	100
Lighting Field	Body Mod	blast 4+ to hit R=0cm	50
Radiated	Body Mod	6+ fixed save, +2Caf	75
Regeneration, greater	Body Mod	See description	100
Regeneration, lesser	Body Mod	See description	50
Resilient	Body Mod	+1 Wound	25
Shielded: N-field(2)	Body Mod	N-field(2)	25
Shielded: N-field(4)	Body Mod	N-field(4)	50
Shielded: N-field(6)	Body Mod	N-field(6)	75
Shielded: Scatter field	Body Mod	Scatter Field	50
Spiked	Body Mod	+2 Caf	25
Urticated	Body Mod	PD (10)	25
Ranged Weapons			
Acid/poison projection	Ranged	Barrage	50
Biopulse	Ranged	Beam Weapon	50
Death Ray	Ranged	Beam Weapon	25
Eye Beams	Ranged (head)	Beam Weapon	50
Fiery Breath	Ranged (head)	Flamer	25
Gamma-Gun	Ranged (arm)	Projectile	75

Rocket Spike	Ranged	Missile	50
Plasma Ray	Ranged	Beam Weapon	75
Spike Shooter	Ranged	Projectile	50
Vibrobeam	Ranged	Area Effect attack	75

Mega-Monster Weapon/Modification Description Table

Weapon	Range	Attack	To hit	Save Modifier	Other
Close Combat Weapons					
Claw					+1d6 CaF
Club/sword/etc	10cm	1	3+	-3	+1d6 Caf
Oversized Jaws/Pincers					+1d6 CaF, head only
Ram Head					Ram Attack, 6+ fixed save on head
Scorpion Tail	0cm	1	3+	-4	Attacks before close combat
Shield	The giant gains a +1 to all armor saves from attacks coming from the forward 90 degree and always saves on a 6.				
Spiked Tail					+3 CaF
Tentacles					Never Outnumbered
Body Modifications					
Adrenal Reserve					+3d6cm on one charge
Augmented Weapon					Additional +1 caf, +1 damage, or -1 save for a single weapon. Can be taken multiple times, but only once per weapon and costs one body modification per augmentation.
Bio-battery	12cm template	Template	4+	-1	Area effect attack centered on the beast with a radius of 12cm. Anything at least half under is hit on a 4+. Requires one turn to recharge.
Decimator					May attack at ½ caf during move if not pinned. As long as the Monster wins Close combat it may continue moving
Flying Leap			3+	-5	20+(1-10)d6cm
Heavy Armor I					+1 Armor Save
Heavy Armor II					+2 Armor Save
Impervious					Always saves on 5+
Lighting Field	Base to Base	Base to Base	4+	-1	In close combat phase, before close combat.
Radiated					6+ fixed save, +2Caf
Regeneration, greater					See description
Regeneration, lesser					See description
Resilient					+1 Wound
Shielded					Scatter or N-field
Spiked					+2 Caf

Urticated	15cm	10	6+	0	360 degree field of fire
Ranged Weapons					
Acid/poison projection	75cm	3+1d6bp	3+1d6bp	-2	Barrage
Biopulse	75cm	3	4+	-1	
Death Ray	75cm	1	4+	-2	
Eye Beams	75cm	2	3+	-2	
Fiery Breath	Template	Template	3+	-1	Ignore cover
Gamma-Gun	100cm 75cm	1 7bp	3+ 7bp	-3 0	Direct fire or barrage. Gamma Mega-monster only.
Rocket Spike	100cm	1	2+	-5	+2 on damage roll, single shot. Drops 1d6 shields on shielded target but reduces save modifier by one point per shield.
Plasma Ray	75cm	4	3+	-3	First fire only
Spike Shooter	50cm	5	5+	-1	
Vibrobeam	100cm	Straight line	5+	-1	Hits anything along line

Optional CaF Weapon Descriptions:

Claw: The beast has an over-sized claw capable of ripping apart titans and crushing superheavies.

Club/Sword/Etc: The beast has been given a gigantic weapon to use in combat. It increases the beast's close combat capability, but also gives the beast the capability to attack nearby units if not engaged in close combat.

Oversized Jaws/Pincers: Head Only. The beast's head has massive teeth, oversized jaw, or giant pincers capable of crushing tanks.

Ram head: Only used on a successful charge. The Monster gains +1d6 caf for this round only. If his opponent is a titan and it wins caf, it knocks the titan over, destroying it. The ram will autohit a building and force it to save at a -6 or be destroyed. If the Monster destroys a building in this fashion, it may continue its charge, but loses its caf and knockdown bonuses.

Scorpion Tail: The beast has a monstrous tail used to attack targets in close combat. During the close combat phase, before close combat, nominate one target. The target is hit on a 3+ and must save with a -4 save modifier.

Shield: The Gamma carries a giant shield used to deflect incoming shots. The Gamma gains a +1 to all armor saves from shots originating in its forward 90 degree angle. In addition, the gamma always saves on an armor roll of a 6 (6+ fixed). The 6+ fixed armor save is allowed in close combat, but only the 6+ (not the normal armor save).

Spiked Tail: The creature's tail is covered in adamantine spikes. It uses its spiked tail to beat close combat targets into a bloody pulp.

Tentacles: The beast is covered with tentacles both large and small. Although it adds no close combat bonus, the beast is never outnumbered in close combat and multiple attackers do not gain any bonus.

Optional Body Modification Descriptions:

Adrenal Reserve: The beast has a special store of adrenaline. It can use this once during the game to gain additional movement on a charge.

Augmented Weapons: The weapon system has been augmented with mutation, bionics, radioactive beans, etc. Each weapon system may only be modified once.

Bio-battery: Area effect attack centered on the beast with a radius of 12cm. Anything at least half under is hit on a 4+. Requires one turn to recharge.

Decimator: The beast is a rampaging monster, stepping on tanks and crushing infantry as it moves. It can attack at ½ caf during move if not pinned. As long as the monster wins close combat it may continue moving.

Flying Leap: The beast is capable of making a single, incredible leap. The creature must have charge orders to make a flying leap. The player announces how many d6 (1-10) will be used before rolling and the direction. The results of the roll are added to 20cm in the

direction nominated. Anything caught under the beast as it lands will be hit on a 3+ with a -5 save modifier. If the beast comes down in unpassable terrain, it takes an automatic critical hit to each leg.

Heavy Armor: The beast's armor has been augmented to increase its resistance to damage. The maximum the armor save can be modified to is 1+.

Impervious: The beast has a heavily reinforced interior allowing it to withstand even the heaviest weapons. The beast will always save on a 5+ regardless of save modifier.

Lightning Field: The beast is covered in an aura of crackling power. Any unit in base to base with the beast at the beginning of the close combat phase is hit on a 4+ and must make an armor save with a -1 penalty.

Radiated: The beast's armor save can never be modified beyond 6+. In addition, the beast gains +2 caf for close combat. This cannot be combined with impervious.

Regeneration, lesser: May regenerate a wound on a 4+ at end of turn. May regenerate damaged system on a 5+.

Regeneration, greater: May throw one die per wound (up to a maximum of 3 wounds) to regenerate wounds. On each 4+ one wound is removed. May regenerate damaged system on a 4+, may regrow a destroyed system (except head) on a 6+.

Resilient: The beast is in excellent health and can take one additional wound. This modification can be taken multiple times.

Shielded: The unit gains an N-Field or scatter shield. This option can only be picked once per monster.

Spiked: The beast is covered with long, sharp spikes. This gives the beast extra damage in close combat.

Urticated: The beast has razor sharp darts covering it's body. The beast can flex it's muscles causing the darts to skewer nearby attackers.

Optional Ranged Weapons:

Acid/Poison Projection: The beast is capable of projecting a large volume of caustic fluid over an area. Use a regular barrage template. The acid can be fired indirectly using the normal rules.

Biopulse: The creature can fire beams of concentrated energy capable of punching through armor.

Death Ray: The creature has the bargain basement version of an energy beam. It has the same capability as most main battlecannons.

Eye Beams: The creature's eyes can store and then release light energy with high accuracy and devastating effects.

Fiery Breath: The beast can breath fire! Treat as a flamer.

Rocket Spike: The beast has a single, giant, rocket propelled, barbed spike. It can only fire the rocket once, but with devastating results. A successful hit versus an unshielded target results in a -5 save modifier. If the target is shielded, the spike will knock down the shields at a cost of it's save modifier. Each shield knocked down reduces the save modifier by one point. A titan hit by the spike suffers a +2 penalty to the damage roll.

Plasma Ray: The beast is capable of producing and projecting plasma. The power requirement is very high and the beast can only manage to fire the plasma ray if it is standing still. As such, it may only be fired on first fire orders.

Spike Shooter: The spike shooter is a rapid fire projector that fires explosive rounds at targets.

Vibrobeam: The beast uses ultrasonic waves concentrated down a single line to liquify it's targets. Anything under the line can be hit, including buildings.

Mega-Monster Damage:

Each time a Mega-monster fails its save roll, it will take a single wound. Roll 1d6 for each wound taken, on a roll of a 6, the wound causes a critical hit. Roll on the location table and then roll 1d6 to determine the extra damage. For each wound taken, the Mega-monster loses 1 caf point. When a Mega-monster reaches zero wounds, it becomes crippled. Its movement rate and caf is halved. All further unsaved hits automatically cause a critical hit. Note: if the Mega-monster has regeneration, it can reverse these effects. Weapon hits are randomized between all non-destroyed weapons.

Roll	Location	Leg/Wing*	Body	Armored Void	Weapon	Head
1	Leg/wing	Damaged, speed halved and cannot enter difficult terrain.	+1 to all future rolls in this area.	No Additional Damage	Weapon damaged, may use on 4+	Stunned, Monster must use random orders next turn (first fire, charge, or advance)
2	Body					
3	Body	Damaged, Roll d6 in each end phase; subtract 2 for charge orders, 1 for advanced orders. A result of 0 or less, the leg snaps and monster falls (destroyed).**	+ 1 additional wound, +1 to all future rolls in this area.	+1 to all future rolls in this area.	Weapon Destroyed, +1 additional wound on a 4+	Brain Damage. The Monster may only move/shoot on a 4+. Any head weapon destroyed.
4	Armored Void					
5	Weapon					
5	Weapon	Destroyed leg. The monster may no longer move or turn. If flying, the monster falls and takes 1d3 wounds from low or 1d6 wounds if flying high.**	Internal Organs damaged, Monster can only move or shoot on 4+, +1 additional wound.	+1 additional wound	Weapon destroyed and +1 additional wound and suffers another random critical hit on a 4+	Brain Destroyed. Monster rampages 2d6 cm in a random direction and then falls down dead.
6	Head	Destroyed leg, monster crashes to the ground and is destroyed.**	Body rupture, internal organs spill out. Mega-monster dies.			

* Betas treat leg hits as (1-3) Body or (4-6) Armored Void. Epsilons Treat all leg hits as Armored Void Hits.
** Alphas treat the first result of 3-6 as a 1 due to their multiple legs. Deltas completely ignore the first two leg hits of any result.
All rolls to damage an Omega monster suffer a -1 penalty.

Soul Spider Army List

Company Card	Composed of	Instinct	Break point	Moral	Victory Points	Cost
Abomination Swarm	30 Abomination stands	charge	15	2	9	800
Arachnid/Bug Swarm	30 Bug Stands	charge	15	2	6	400
Armored Beast Swarm	1 Armored Beast Leader 9 Armored Beasts	charge	5	2	5	450
Large Beast Swarm	1 Large Beast Leader 15 Large Beasts	charge	8	2	3	300
Shamblers Swarm	30 Shamblers	varies	15	2	3	300
Any Mega-Monster	One Mega-Monster	Command	Various	1	Various	Various
Gigantic Beast Swarm	1 Gigantic Beast Leader 2 Gigantic Beasts	Charge	2	2	4	300
Radioactive Beast Swarm	1 Radioactive Beast Leader 2 Radioactive Beasts	First Fire	2	2	5	500
Support Cards						
Abomination Squad	10 Abomination stands	charge	5	2	3	250
Arachnid/Bug Squad	10 Bug stands	charge	5	2	2	150
Armored Beast Squad	3 Armored Beasts	charge	2	2	2	150
Black Widow Squad	5 Black Widows	Independent	3	4	2	200
Dragon	1 Dragon	Independent	1	3	2	200
Gigantic Beast	One Gigantic Beast	charge	1	2	2	150
Hydra	1 Hydra	Independent	1	2	3	200

Large Beast Squad	5 Large Beasts	charge	3	2	1	100
Radioactive Beast	One Radioactive Beast	First fire	1	2	3	250
Shambler Squad	10 Shamblers	varies	5	2	1	100
Soul Reaper	One Soul Reaper	Independent	1	2	2	200
Wolf Spider Squad	5 Wolf Spiders	Independent	3	4	2	150
Special Cards						
Blob	One Blob	No orders	1	-	3	200
Lambda-Swarm Progenitor	One Swarm Progenitor (must be attached to a swarm)	Command	1	1	1/100 points	250+
Master Geneticist	One Master Geneticist	Command	1	2	2	150
Shepard	One Shepard	Command	1	4	2	200
Tormenter	One Tormenter	Command	1	4	3	300
Command Howdah	Must be attached to a megamonster	As monster	1	2		25
Defense Howdah	Must be attached to a megamonster	As monster	1	-		25
Offensive Howdah	Must be attached to a megamonster	As monster	1	-		100
Greater Howdah	Must be attached to a megamonster	As monster	1	-		200
Bombardment Howdah	Must be attached to a megamonster	As monster	1	-		250

Soul Spider Unit Command/Instinct List

Unit	Command/Independent/Instinct
Black Widow	Independent, can give orders but is not considered command
Wolf Spider	Independent, can give orders but is not considered command
Master Geneticist	Command
Abominations	Uncontrolled abominations always charge toward the closest enemy living unit. If they are uncontrolled and there are no living units on the board, they will simply stay where they are, even if being shot (but they will gladly fight back in close combat).
Arachnid/Bug	Bugs will charge toward the closest living unit if uncontrolled. If there are no living units, they will charge toward any enemy unit that moves/fires.
Armored Beast	Uncontrolled beasts will charge toward the nearest living enemy unit. If there are no living units, they will charge toward any enemy unit that moves/fires.
Shambler	Shamblers in command follow orders as normal. Uncontrolled shamblers will charge toward any living unit within 20cm or walk toward the nearest living unit at their base movement rate if their target is farther than 20cm. If they are uncontrolled and there are no living units on the board, they stand where they are, even if shot (but will fight back in close combat)
Large Beast	If in command, they follow orders as normal. If out of command, they charge toward the nearest enemy unit in sight.
Shepard	Command
Soulreaper	Independent
Dragon	Independent

Gigantic Beast	If in command, they follow orders as normal. If out of command, they charge toward the nearest enemy unit in sight.
Hydra	Independent
Radioactive Beast	If in command, they follow orders as normal. If out of command, they go on first fire orders.
Blob	Independent
Tormenter	Command
Mega-Monster	Independent, units in sight may copy Mega-Monster's orders.

Brain Bug Psi-cards

Frenzy +1 CaF to one squad or model (not swarm) for one combat.	Frenzy +1 CaF to one squad or model (not swarm) for one combat.	Frenzy +1 CaF to one squad or model (not swarm) for one combat.	Contest of Wills Range 50cm 4+ to hit Roll (1d6) 1-4 target immobilized 1 turn. 5-6 target dies	Psi Scream Barrage 6cm Range 50cm 1 Barrage point Psy attack, no armor save Units hit die unless psychic save	Warp Bubble Unit/squad is protected by a warp field. Any unit attempting to shoot the protected models suffer a -1 to hit.	Brain Scramble Reassign orders to any unit (friend or foe) within 25cm. Play during order phase.
Brain Scramble Reassign orders to any unit (friend or foe) within 25cm. Play during order phase.	Fear Range 50cm Unit must make a moral test or go on Fall Back orders.	Fear Range 50cm Unit must make a moral test or go on Fall Back orders.	Fear Range 50cm Unit must make a moral test or go on Fall Back orders.	Teleport Move any unit within 25cm up to 15cm. (no titan, superheavy, or praetorian)	Psi Shield Unit gains an additional 4+ armor save for one turn. Must be taken first.	Change Fate Force a reroll of any one d6 roll. Second result must be used.
Change Fate Force a reroll of one d6 roll. Second result must be used.	Change Orders May change any friendly unit's orders after all order have been revealed.	Psi-Healing Regenerate one living unit within 25cm of the brain bug or heal 1 wound on a mega-monster.	Foresight Add +1 to initiative die roll for a single turn, must be used before the dice are rolled.	Foresight Add +1 to initiative die roll for a single turn, must be used before the dice are rolled.	Death Wave Use flamer template, no cover bonus, 4+ to hit, -1 save modifier. Counts as a psychic attack.	Oblivion Beam Range 75cm, 1 attack, 3+ to hit, -3 save modifier. Psychic physical attack.

Master Geneticist Cards

Infiltrated	Infestation	Pox	Bonus Mutation	Regeneration
Pick one enemy infantry unit (max of 10 models) and roll d6 per stand. On a roll of a 6 the unit becomes a shambler and charges the nearest enemy unit.	Pick a terrain feature or building. It becomes infested. Any model in or moving through the terrain suffer combat during close combat. (One attack with 0 CaF)	Place a barrage template anyplace on the table and scatter once. Any model under the template it hit on 4+ during Close Combat, no save mod. Template stays in place. Units killed become shamblers.	Target living model or unit (up to 10 models) gains +1 CaF, +1 armor save, or skimmer for the rest of the game.	Target living model or unit (up to 10 models) gains a fixed 4+ regeneration roll.
Burn Out	Infestation	Viral Spray	Bonus Mutation	Detonate
Target unit turns into unstable, frenzied, killers. Gain +1 CaF, roll d6 per model at end phase, on 1 remove unit, 2-5 add +1 CaF. Award Victory Points for unit to enemy upon playing.	Pick a terrain feature or building. It becomes infested. Any model in or moving through the terrain suffer combat during close combat. (One attack with 0 CaF)	Geneticist gains a flamer template attack of viral fluid that melts living opponents. (Flamer Template, 3+ to hit, -1 save, no cover, no regen.)	Target living model or unit (up to 10 models) gains +1 CaF, +1 armor save, or skimmer for the rest of the game.	Target friendly model explodes at the end of close combat! (barrage temp. 5bp, -2 sv mod.)

Oturuk Hive Army

Oturuk Hive Army Organization

The Oturuk Hive army uses the same basic organization as most armies. The army is composed around company cards. Each company card can bring up to 5 support cards and up to one special card. All psychological rules apply including unit cohesion and break checks. The army must be at least 75% composed of units from the Oturuk army list. Up to 25% of the army can be borrowed from allied army lists (Soul Spider or Eye Horrors). Oturuk units can take orders from any Xenos command units, but cannot give any orders to any other Xenos army.

Oturuk Hive Unit Descriptions:

Hive Prince: The hive prince is one of the original generals of the Oturuk army. Still armed with their ancient weaponry from the master race, they lead their armies in the endless cycle of invasion and construction. Although not powerful in hand to hand, they are deadly accurate at range.

Champion: A champion is genetically modified Oturuk used as a line commander. It is bigger, stronger, and tougher than average Oturuk.

Hive Brain: A hive brain is a soul spider modified Oturuk capable of bending the warp to its will. It lacks the multiple flashy psi powers of other races, but still has a variety of capabilities. The first is a blast of psychic energy fired during the psychic phase. This is a physical manifestation of power and psy saves are not allowed (although regular armor saves are). The second use is the capability to read the intentions of enemy minds. Once per game the Oturuk player may add +1 when rolling the initiative die, this must be announced before rolling the die. The final power is the capability to tap into the hive mind of the Oturuk to give orders. The Hive Brain is capable of giving orders to any unit with 50cm of their position, this does not require line of sight.

Hive Drones: A hive drone is an alien humanoid with a thickly armored carapace, huge multifaceted eyes, and powerful claws. They are slower than the Oturuk, but are capable of ripping apart tanks. In the hive, they are used as mindless workers. On the field of battle, they are mindless killers. Hive Drones are immune to psychology and if out of command, they simply stay where they are unless attacked. If out of command and shot at, they will charge toward that unit on the next move. If they are attacked in hand to hand, they will defend

themselves.

Infantry: The common Oturuk is an unusual sight. They are a snouted, partially carapaced, bug eyed, hunchbacked humanoid. They are incredibly fast, but not very hardy in hand to hand. They are usually covered in earthen colored, hooded robes and use las-rifles as their preferred weapon.

Long Guns: The Long Guns are another genetically modified version of a common Oturuk. Using two enlarged complex eyes as well as 5 distance sensing eyes, they are capable of targeting at extreme ranges. Paired with heavier lasguns, the long guns are capable of devastating other enemy troops and lightly armored vehicles at distance.

Vampire: The vampire is a battlesuit used as mobile fire support for Oturuk troops. It is fairly heavily armored and mounts a deadly gatling laser.

Walker: The walker is an insect like robot used for infantry fire support. It's cigar shaped body uses 6 legs to move over terrain and has a bug-like head mounted in the front. The lascannon is mounted to the dorsal side of the body. The walker is a robot and is immune to all psychology and non-physical psychic powers. The walker does not need to be in range of any command unit, but must be given all of it's orders before the battle begins (advance on turn one, first fire on turn two, etc, for a full 7 turns).

Death Hopper: This odd mechanical unit is an ornithopter. Although capable of flight, it is only able to stay aloft for a short period of time. This results in the vehicle making hops. The vehicle is considered a flier while moving, but must end its move on the ground. It may take off and head in any forward direction. When it lands it is capable of facing any direction, but must land in passable terrain. Failure to land in passable terrain will cause the vehicle to be destroyed.

Ironduke: The ironduke is a floating command vehicle resembling a metallic dirigible. Although slow moving, it gains the move and shoot ability of the Squat superheavies (cannot charge, may move up to 20cm maximum, always fires on fire fire). The true power of the vehicle is not the weaponry, but the capability to give any Oturuk unit, that can see the ironduke, orders. For this reason alone, it is often the first unit targeted.

Blazer Tank: The blazer is the most common battle tank used by the Oturuk. It has armor comparable to a Lemman Russ and sports two lascannons.

Comet Scout Tank: The Comet is a very fast skimmer used to harass lightly armored targets.

Cosmos Tank: The Cosmos is a heavy support tank armed with a rack of armor melting plasma missiles. The Cosmos is used to rain destruction down upon the enemies of the hive.

Nova Tank: The Nova tank sacrifices some of its armor to be able to mount a disintegrator. With this weapon, the Nova is dangerous against both closely packed infantry and battle tanks.

Thorg Tank: The Thorg tank is a heavily armored main battle tank that uses the Quantum beam as its primary armament. The quantum beam is fired using stored power. The main reactor of the tank feeds the power into a storage container. The less power the tank uses for movement, the more power can be stored up. For each point stored, the beam gains a -1 save modifier on a successful hit. All stored power is used when the Quantum Beam fires. On a charge order, the power that normally feeds into the storage tank is instead shifted to the hull of the tank. The extra power temporarily increases the damage of the vehicle in close combat (+1 caf for the first close combat). The maximum power that can be stored is 4 points. The Thorg tank can store 1 point on advance orders or 2 points on first fire orders.

Dracolisk Walker: A hive prince on a joint mission once marveled at the destruction caused by a mega-beast. Upon returning to base, the prince inspected his forces and could not find anything with similar capabilities. He ordered his best technicians to pattern a monstrous mechanical beast that he could use. They created a heavily armored, 6-legged robo-beast that could breath fire and shoot laser beams out of it's eyes. The dracolisk has been a standard superheavy every since.

Ghoul Tank: The Ghoul is an upgraded, incredibly heavily armored superheavy version of the Nova tank. It mounts macro version of the standard disintegrator cannon and multiple scatter lasers to keep enemy troops at bay.

Headhunter Tank: The headhunter is an odd superheavy that plays on the Oturuk's love of long ranged, accurate laser weapons. The sniper superheavy laser is extremely accurate and can target any unit, even ignoring the command rule. It never rolls for deviation on titan damage templates. However, it lacks the power to punch through even light armor.

Terminus Heavy Fire Support Platform: The terminus was designed to bring the potent thundergun onto the battlefield. It is the only superheavy in the Oturuk army to have a shield.

Robo-10,000 Knight: The Robo-10,000 knight is an ancient knight design used by the Oturuk. It is easily made with only minor

technology and works well for its cost, but it is no match for the more technologically advanced knights of other races.

Oturuk Drop Fortifications: The Oturuk are known to use heavy fortifications, dropped from low orbit, to invade a planet. These fortifications are capable of carrying troops safely down to the surface. Each purchased drop fortification can be placed in the Xenos starting zone at the beginning of the game or can be assigned to drop at a random later turn. If chosen to drop at a later turn, roll 1d3+1 to see which turn's movement phase the building lands. The buildings can land any place on the Oturuk player's half of the board, but not within 20cm of a strategic marker. The fortification can fire on the turn it lands. The Black Tower is capable of holding a single infantry support card, the Fortress can hold up to three infantry support cards, and the Citadel can hold up to 5 infantry support cards or a company card.

Infantry units in the building are capable of firing out and gain the same bonus for cover as a fortified building. All weapons on the fortification have a 360 degree field of fire.

Oturuk Units:

Unit	Move	Save	CaF	Weapon	Range	Attack	To Hit	Save Mod	Special
Infantry									
Hive Prince	15cm	6+	+2	Beam rifle	75cm	1	3+	-1	Command
Champion	15cm	None	+1	Lasguns	50cm	1	4+	-1	Command
Hive Brain	15cm	6+	0	Psyblast	35cm	1	4+	-2	Command, Psy
Hive Drone	10cm	6+ fixed	+4	Claws					infantry
Infantry	15cm	None	-1	Lasguns	50cm	1	5+	0	infantry
Long Guns	15cm	None	-1	Beam rifle	75cm	1	4+	-1	infantry
Vampire	15cm	5+	+1	Gatling laser	50cm	3	5+	0	Dreadnought
Spider Walker	10cm	6+	0	Blaster Beam	75cm	1	5+	-2	Infantry, robot
Fliers									
Death Hopper	35cm	5+	+1	Lasguns	50cm	2	5+	0	Ornithopter
Ironduke	20cm max	2+ all around	+2	Lascannons Scatterlaser Plasma Bomb	75cm 25cm 0cm	4 3 5bp	5+ 5+ 5bp	-1 0 -3	First Fire, command relay, 360 degree field of fire
Tanks									
Blazer Tank	20cm	3+	+2	Lascannons	75cm	2	5+	-1	vehicle
Comet Scout Tank	30cm	4+	+1	Scatterlaser	25cm	3	5+	0	skimmer
Cosmos Tank	15cm	4+	0	Plasma Missile	100cm	1	3+	-3	
Nova Tank	20cm	4+	+1	Disintegrator	75cm 25cm	1 Temp	4+ 5+	-2 0	vehicle
Thorg Tank	20cm	3+	+2	Quantum Beam Lasguns	75cm 25cm	1 1	4+ 5+	* 0	skimmer.
Superheavies									
Unit	Move	Save	CaF	Weapon	Range	Attack	To Hit	Save Mod	Special
Dracolisk Walker	15cm	1+	+8	Heavy Flamer Lascannons	Temp 75cm	Temp 2	3+ 5+	-2 -1	Superheavy, walker, flamer ignores terrain
Ghoul Tank	10cm	1+	+4	Heavy Disintegrator Scatterlasers	100cm 25cm	1 Temp 6	3+ 5+ 5+	-3 -1 0	Superheavy
Headhunter	10cm	1+	+4	Sniper Laser Lascannons	125cm 75cm	1 2	2+ 5+	0 -1	Superheavy, sniper laser can target any

				Scatterlaser	25cm	3	5+	0	visible unit on first fire ignoring command rule.
Terminus	10cm	2+	0	Lascannon Thundergun	75cm 100cm	1 1	5+ 3+	-1 *	N-field (4), superheavy
Robo-10,000	20cm	2+	+5	Blaster	50cm	1	4+	-2	Knight, superheavy
Titans									
Exterminator	20cm	Varies	+8	2 Light Arm 1 Heavy Back					Titan, command relay, N-field (4) or Scatter field.
Hecaton	20cm	Varies	+8	2 Light Arm 3 Light Back					Titan, command relay, N-field (4) or Scatter field.
Drop Fortifications									
Black Tower	-	4+ (2d)	-	Titan Weapon Choice	-	-	-	-	Building save, N-field (3), command, troops, always first fire.
Fortress	-	3+ (2d)	-	Titan Weapon Choice Lascannons Plasma Battery	- 75cm 100cm	- 4 5bp	- 5+ 5bp	- -1 -2	Building save, N-field (4), command, troops, always first fire.
Citadel	-	2+ (2d)	-	Titan Weapon Choice Lascannons Plasma Battery	- 75cm 100cm	- 6 7bp	- 5+ 7bp	- -1 -3	Building save, N-field (6), command, troops, always first fire.

Oturuk Army List

Company Card	Composed of	Break point	Moral	Victory Points	Cost
Oturuk Standard Company	3 x Oturuk Infantry platoons 1 x Champion	15	3	6	600
Oturuk Support Company	2 x Oturuk Long Guns platoons 1 x Oturuk Infantry platoon 1 x Champion	11	3	7	500
Oturuk Mechanized Company	2 x Vampire Detachments 1 x Walker Detachment 1x Champion	7	3 -	6	600
Blazer Tank Company	9 x Blazer Tanks 1 x Blazer Tank command	5	3	6	600
Ghoul Tank Company	2 x Ghoul Tanks 1 x Ghoul Command Tank	2	3	6	600
Black Tower	1 x Black Tower	-	1	3	150
Fortress	1 x Fortress	-	1	5	350
Citadel	1 x Citadel	-	1	6	500
Support Cards					
Hive Drones	10 x Hive Drones	5	1	3	300
Infantry Platoon	10 x Oturuk Infantry	5	3	2	200
Long Guns Platoon	5 x Long Guns	5	3	2	150
Vampire Detachment	4 x Vampire	3	3	2	200
Walker Detachment	5 x walkers	3	-	2	200

Death Hopper	5 x Death Hoppers	3	3	3	300
Ironduke	3 x Ironduke Airships	2	3	4	350
Blazer Tank Detachment	3 x Blazer Tanks	2	3	2	200
Comet Scout Tank Detachment	5 x Comet Scout Tanks	3	3	2	200
Cosmos Tank Detachment	3 x Cosmos Tanks	2	3	4	350
Nova Tank Detachment	3 x Nova Tanks	2	3	2	200
Thorg Tank Detachment	3 x Thorg Tanks	2	3	3	250
Drakolisk Superheavy	1 x Drakolisk	1	3	3	250
Ghoul Superheavy	1 x Ghoul Superheavy Tank	1	3	3	250
Exterminator Titan	1 x Exterminator	1	1	1/100	200+
Hecaton Titan	1 x Hecaton	1	1	1/100	225+
Robo-10,000 Detachment	3 x Robo-10,000 Knights	2	3	2	200
Special Cards					
Hive Command	1 x Hive Prince 4 x Long Guns	3	3	2	200
Hive Brain	1 x Hive Brain 2 x Infantry stands	2	3	1	100
Champion	1 x Champion	1	3	1	50
Headhunter Superheavy	1 x Headhunter	1	3	2	200
Terminus	1 x Terminus	1	3	3	300

Exterminator

The Exterminator is a light titan similar in design to a heavy, hunchbacked Warhound. The basic rig contains 3 weapon mounts. The two “arm options” are light weapon mounts with a single heavy mount on the back. Although a light mount can be chosen for the back mount, it is seen as insulting by the hive prince owning such a vehicle and only used for specific reasons of lack or resources.

Titan	Movement	CaF	Shields	Weapon Options	Cost
Exterminator	20cm	+8	Choice: Scatter Field or N-field (4)	2 x Arm 1 x Back	200+
Weapon	Type	Location	Fire angle	Description	
	light	Right arm	Right 90		
	light	Left arm	Left 90		
	Heavy	Back	Fwd 180		

Exterminator's Hit Location Chart

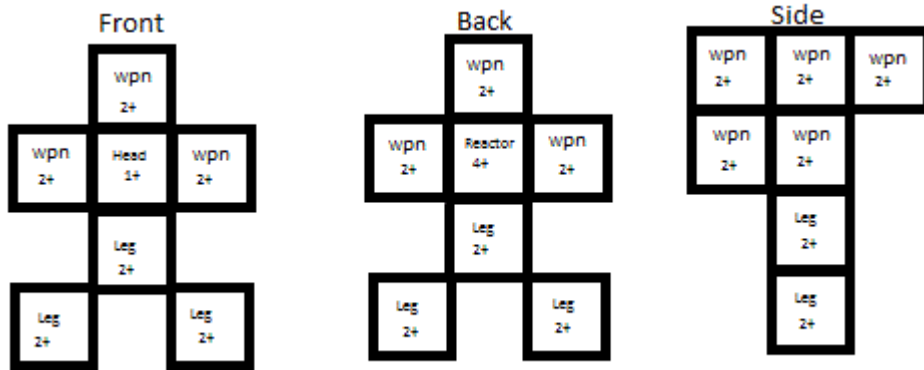

Damage Table

D6	Head	D6	Weapon	D6	Reactor	D6	Leg
1-2	Damaged. CAF halved, 4+ to give titan orders.	1-2	Damaged, may only fire on a 4+	1-2	Damaged	1-2	Damaged, speed halved and cannot enter difficult terrain.
3	Crippled. CAF halved for the rest of game.	3-4	Destroyed	3-4	Crippled	3-4	Damaged, Roll d6 in each end phase; subtract 2 for charge orders, 1 for advanced orders. A result of 0 or less, the leg snaps and titan falls (destroyed).
4	Crippled. CAF halved, 4+ to give orders for rest of game.	5	Weapon Blown off	5-6	Reactor Explodes	5	Destroyed leg. The titan may no longer move or turn.
5-6	Head destroyed, titan falls.	6	Weapon blown off and causes additional damage to (1-3) head or (4-6) reactor.			6	Destroyed leg, titan crashes to the ground and is destroyed.

Hecaton

The Hecaton is an odd version of the standard Exterminator. Instead of using two light arm mounts and a heavy back mount, it has five light weapon mounts. There are two light mounts in the arm area and three light mounts on the back. The Hecaton can not use more than three weapons of the same type due to weapon harmonics.

Titan	Movement	CaF	Shields	Weapon Options	Cost
Hecaton	20cm	+8	Choice: Scatter Field or N-field (4)	5 x Arm	225+
Weapon	Type	Location	Fire Angle	Description	
	light	arm-right	Right 90		
	light	arm-left	Left 90		
	light	back-right	Right 90		
	light	back-middle	Fwd 90		
	light	back-left	Left 90		

Hecaton Damage Table

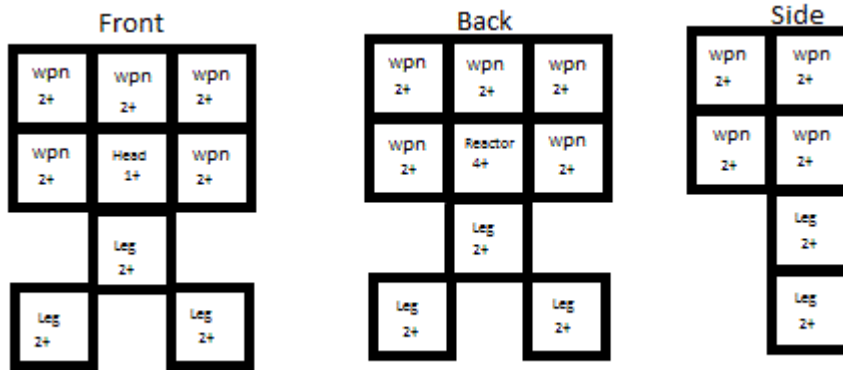

Hecaton Damage Chart

D6	Head	D6	Weapon	D6	Reactor	D6	Leg
1-2	Damaged. CAF halved, 4+ to give titan orders.	1-2	Damaged, may only fire on a 4+	1-2	Damaged	1-2	Damaged, speed halved and cannot enter difficult terrain.
3	Crippled. CAF halved for the rest of game.	3-4	Destroyed	3-4	Crippled	3-4	Damaged, Roll d6 in each end phase; subtract 2 for charge orders, 1 for advanced orders. A result of 0 or less, the leg snaps and titan falls (destroyed).
4	Crippled. CAF halved, 4+ to give orders for rest of game.	5	Weapon Blown off	5-6	Reactor Explodes	5	Destroyed leg. The titan may no longer move or turn.
5-6	Head destroyed, titan falls.	6	Weapon blown off and causes additional damage to (1-3) head or (4-6) reactor.			6	Destroyed leg, titan crashes to the ground and is destroyed.

Oturuk Titan Weapon Options

Weapon	Loc.	Range	Attack	To hit	Save Mod	Special	Cost
Combat Arm	light	Close combat	+1d3 caf				15
Disintegrator	light	75cm	1 template	4+ 5+	-2 0		35
Droth A.P. laser	light	25cm	4	4+	0		25
Fusion Beams	light	35cm	2	3+	-3		25
Tentacles	light	Close Combat		Never outnumbered			25
Twin Lascannons	light	75cm	2	5+	-1		25
Battle Tower	Heavy	50cm 10cm	3 4	4+ 6+	-2 0	360° Fire 360° Fire	50
Triple Laser	Heavy	75cm	3	4+	-1		65
Heavy Disintegrator	Heavy	100cm	1 Temp	3+ 5+	-3 -1		100
Mega-Beam	Heavy	100cm	Template	4+	-1	template	100
Plasma Battery	Heavy	75cm	5bp	5bp	-2	Barrage	75
Plasma Missile Rack	Heavy	100cm	1	3+	-3		85
Quantum Beam	Heavy	75cm	1	4+	*		50
Thunder Gun	Heavy	100cm	1	3+	*	First fire only	75
Xan A.P. Cannon	Heavy	50cm	6	4+	-		50

Unaligned Mercenaries

Arachnossassin

The arachnossassins are an ancient cult dedicated to the ultimate fight. They live and die only for the next conquest, proudly displaying the skulls of their rivals. Although highly trained at close combat, they lack depth perception and have a hard time at ranged combat. To compensate for this, they use a personal invisibility field that gives them a 2+ fixed save versus all direct fire shots. The shield does not protect them in close combat or against area effect weapons. The shield save is taken before it's armor save.

The arachnossassin can be taken as a special card for any army and costs 50 points unless the Xenos army is facing Tyranids. When fighting a Tyranid force, the arachnossassin can be taken as a free card.

Unit	Move	Save	CaF	Weapon	Range	Attack	To Hit	Save Mod	Special
Arachnossassin	10cm	5+	+6	Blaster	50cm	1	6+	-1	Invisibility Field, independent.